



## Technical specifications

Single lane sandwich line

### Capacity

Up to 165 products/minute or **9.900 products/hour**, depending on sandwich size and paper quality

### Electrical Requirements:

Country Specific

### Dimensions

(L)108" x (W) 28,75" x (H) 35"

### Air Requirements:

5,0 Bar

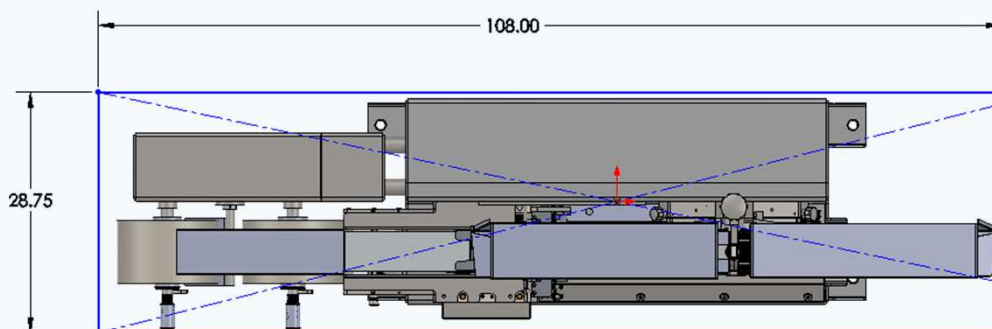



## SL200 Sandwich Line

Big Drum is proud to introduce our newest equipment line, the SL200 Sandwich Filler. The SL200 can be customized to fit your production needs from a single size product non-registered wrap up to a multiple product size with servo drive for registered wrap.

### Key Benefits:

- The frame is a “one-piece” all stainless steel construction for long life and ease of cleaning
- Easy access doors on front & back for maintenance
- Allen Bradley touch screen
- Automatic oiling system
- Speeds up to 165/min depending on sandwich size and paper quality
- Suitable case packer ES300 available

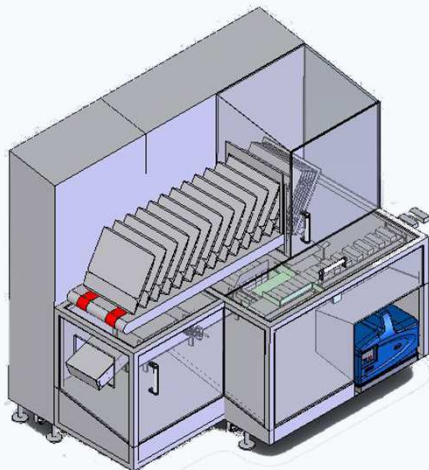

ES300 Cartoner

